



Technical Data

Specification & Capacities

SPX424



CDH: 14,9kW/20Hp



C+: 4,0kW/5,5Hp



2,6 - 8,5m



2400kg

CE
EN 13000

[m] [kg]



SPX424

SPX424 - OVERALL DIMENSIONS

SPX424CDH

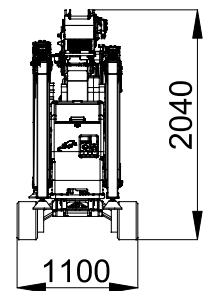
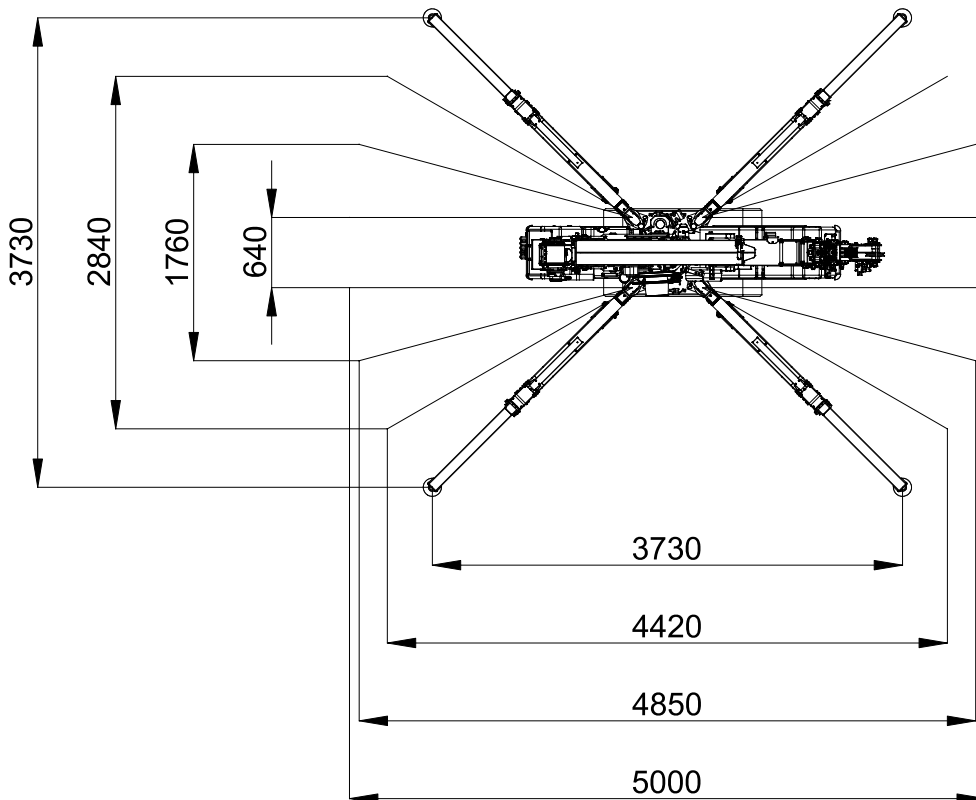
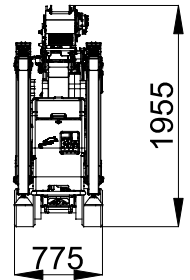
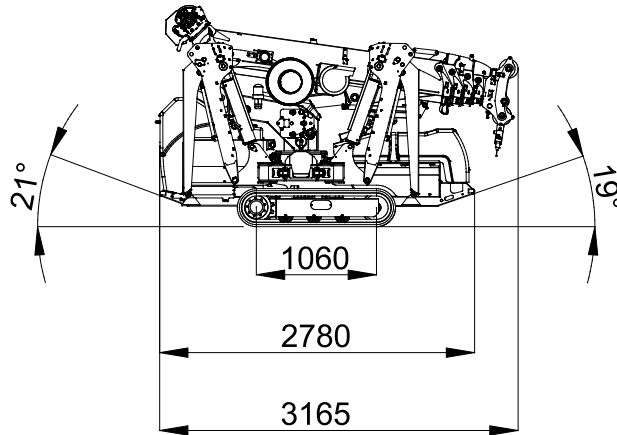

WEIGHTS		Name / version	kg ¹
		CDH, C+	2080
		CDH, C+	200
		SINGLE FALL	27
		MULTIPLE FALL	20
		POWERPACK	45
		800GX	25
		800.1MX	110
		800.2H1MX	170
		MV600	200
		MR800	295
		HA-SPX424	30
	OM400	17	
	WUK-02	1,5	

- ¹: Dry weight
- ²: Engine working limit
- ³: Static lifting

ENGINE		KUBOTA D722-E3B		
		14,9kW 20Hp		
		DIESEL		
		L	10,0	
ELECTRIC		C+: 24V 240Ah C++: 24V 420Ah		
		Li: 24V 288Ah		
		24V-3F 4,0kW 5,5HP		
HYDRAULIC		ISO 6743-4:HFDU with VG46 viscosity class		
		Working temp	<70°C	
		L	35	
MOVEMENTS		km/h	CP: 1,8 C+: 0,72	
		20° (36%) ²		
		kg/cm ²	0,55	
		kg	2200 ³	
		0°/75°		
		s	14	
		360°		
		rpm	1,5	
		m	2,6 - 8,5	
		s	26	



SPX424 – MAIN BOOM

100%

360°

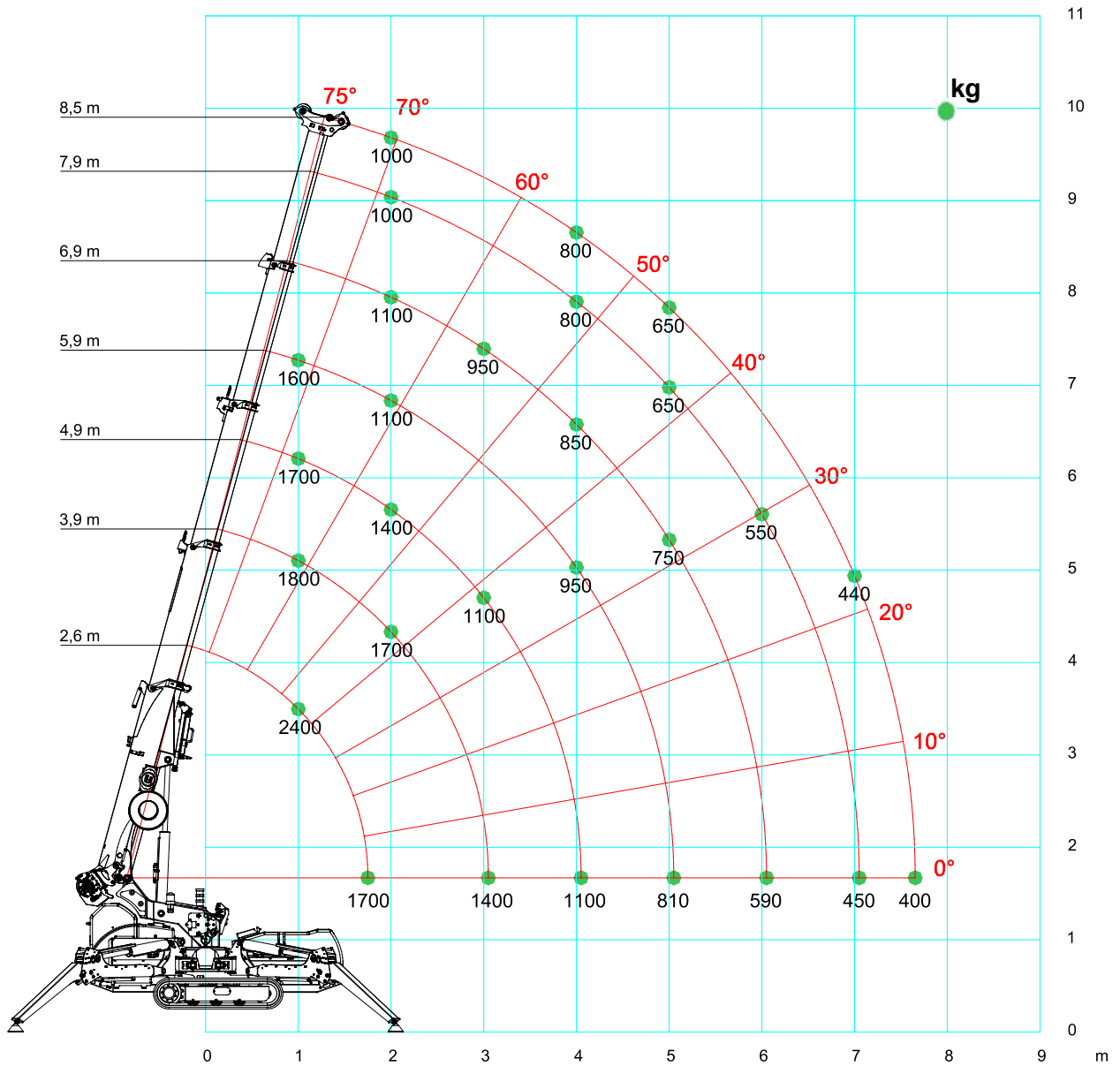
200 kg

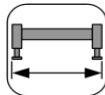
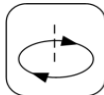

[m] \ [kg]	 MAIN BOOM	 100%	 360°	 200kg	EN		
	2,6	3,9	4,9	5,9	6,9	7,9	8,5
1	2400	1800	1700	1600	1400		
2		1700	1400	1100	1100	1000	1000
3		1400	1100	1000	950	900	900
4			1100	950	850	800	800
5				810	750	650	650
6					590	550	500
7						450	440
7,6							400

LC424_V401_1116_BP_FUNE_CW200_STAB_100

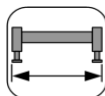
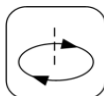
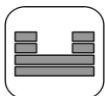
[m] \ [kg]	 MAIN BOOM	 50%	 360°	 200kg	EN		
	2,6	3,9	4,9	5,9	6,9	7,9	8,5
1	2400	1800	1700	1400	1200		
2		1700	1200	1000	900	850	800
3		980	950	900	800	750	700
4			540	530	520	510	500
5				360	340	330	320
6					250	230	210
7						180	160
7,6							150

LC424_V401_1116_BP_FUNE_CW200_STAB_50



SPX424

SPX424 + JIB800GX



100%





360°



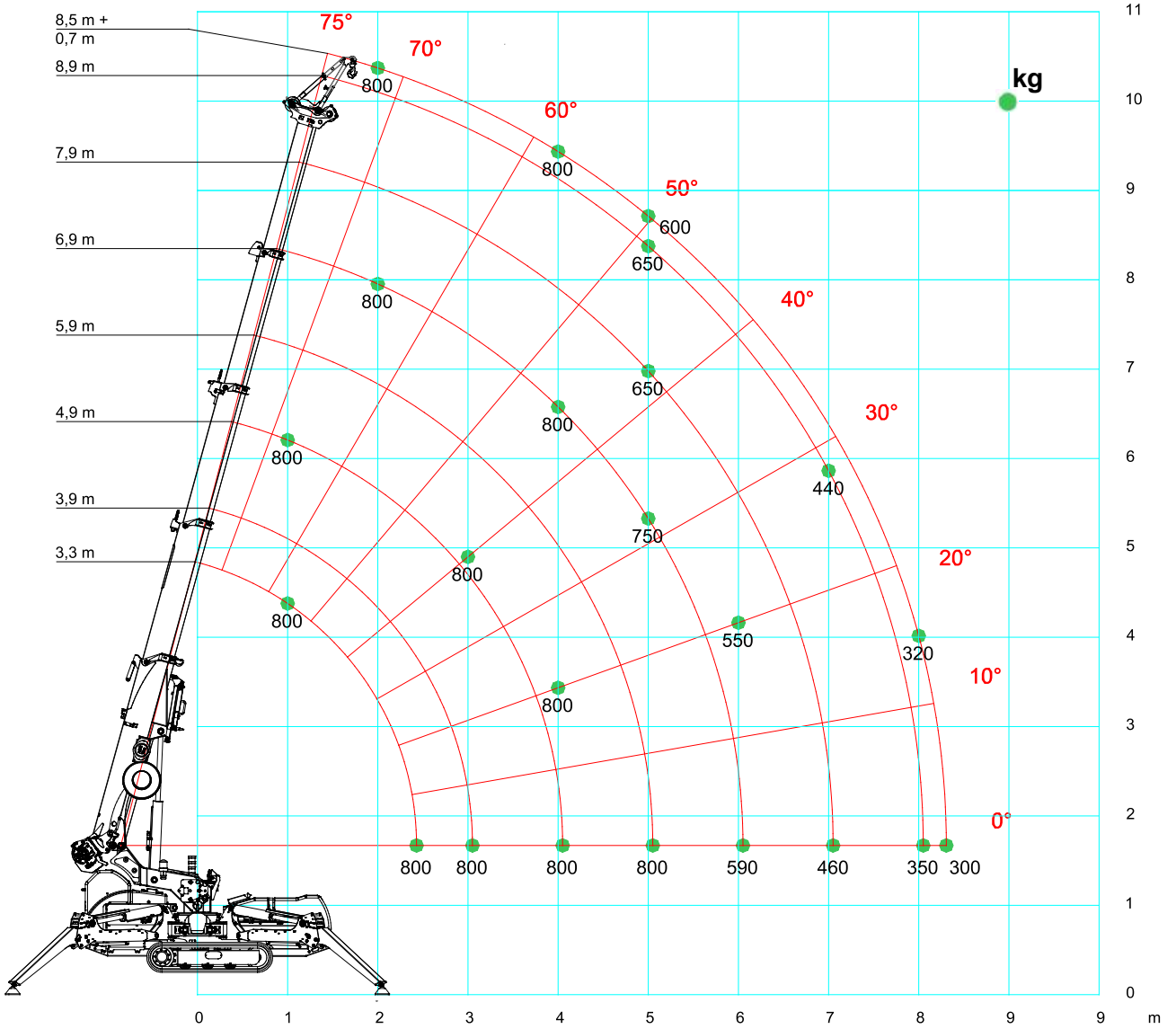

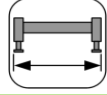
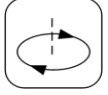
200 kg

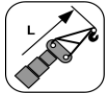
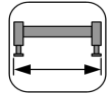
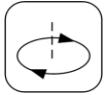
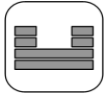

[m] \ [kg]	 JIB800GX	 100%	 360°	 200 kg	 EN			
	3,6	3,9	4,9	5,9	6,9	7,9	8,9	9,2
1	800	800	800	800	800			
2	800	800	800	800	800	800	800	800
3		800	800	800	800	800	800	800
4			800	800	800	800	800	800
5				800	750	650	650	600
6					590	550	500	450
7						460	440	400
8							350	320
8,3								300

LC424_V401_1116_RUNNER_GANCIO_CW200_STAB_100

[m] \ [kg]	 JIB800GX	 50%	 360°	 200 kg	 EN			
	2,9	3,3	4,3	5,3	6,3	7,3	8,3	9,2
1	800	800	800	800	800			
2	800	800	800	800	800	800	800	800
3		800	800	800	800	750	700	700
4			560	550	530	520	510	500
5				370	360	360	350	350
6					250	240	230	220
7						180	170	160
8							130	130
8,3								120

LC424_V401_1116_RUNNER_GANCIO_CW200_STAB_50



SPX424

SPX424 + JIB800.2H1MX



100%





360°



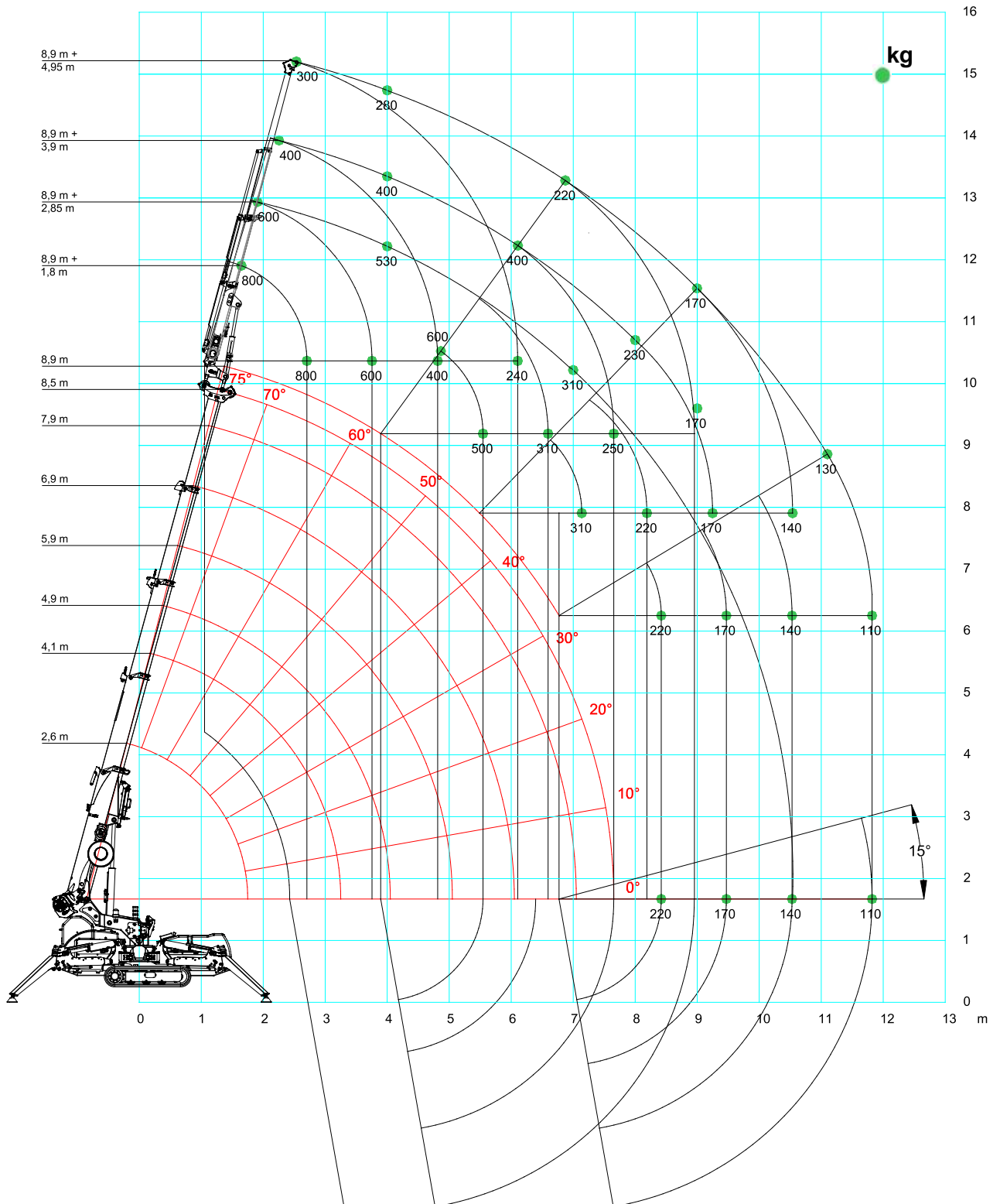

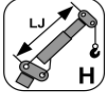
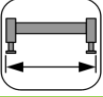
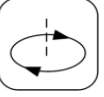
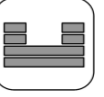
200 kg

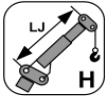
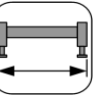
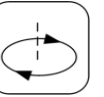
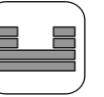

[m] \ [kg]	 JIB800. 2H1MX	 100%	 360°	 200kg	 EN
	1,8	2,9	3,9	4,9	
2	800	600			
3	800	600	400	300	
4	800	600	400	280	
5	680	600	400	260	
6	460	460	400	240	
7	310	310	310	220	
8	230	230	230	200	
9	170	170	170	170	
10		140	140	140	
11		130	130	130	
11,8			110	110	

LC424_V401_1116_JIB2_IDR_FUNE_CW200_STAB_100

[m] \ [kg]	 JIB800. 2H1MX	 50%	 360°	 200kg	 EN
	1,8	2,9	3,9	4,9	
2	800	600			
3	700	600	400	300	
4	420	420	400	280	
5	230	230	230	230	
6	120	120	120	120	

LC424_V401_1116_JIB2_IDR_FUNE_CW200_STAB_50



SPX424

SPX424 + MR800.4-6+4P



100%





360°



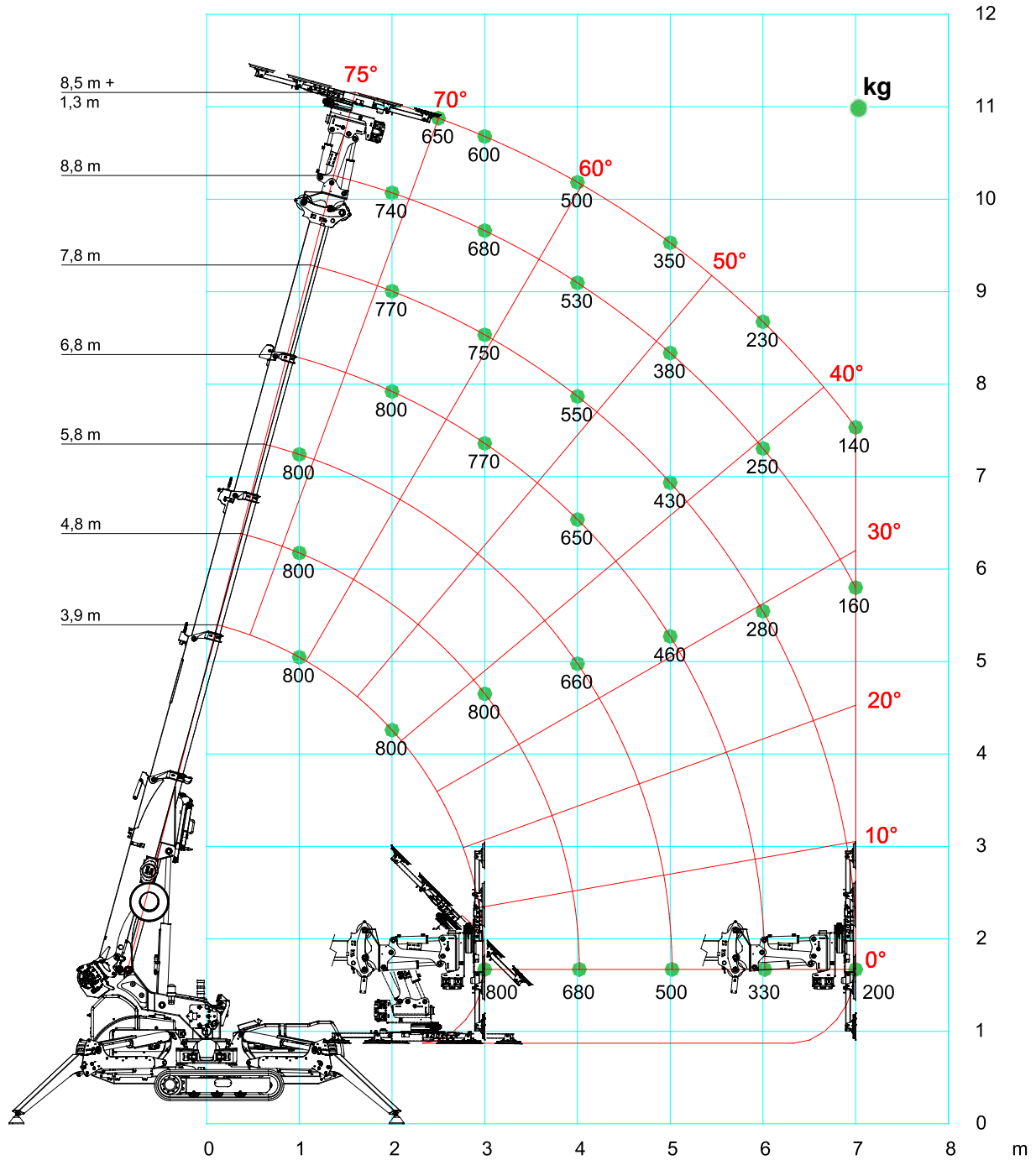

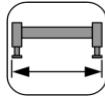
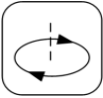
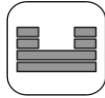
200 kg

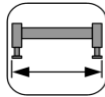
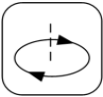
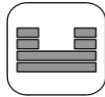

[m] \ [kg]	 MR800.4-6+4P	 100%	 360°	 200kg	 EN		
	3,9	4,8	5,8	6,8	7,8	8,8	9,8
1	800	800	800	800			
2	800	800	800	800	770	740	700
3	800	800	800	770	750	680	600
4		680	660	650	550	530	500
5			500	460	430	380	350
6				330	280	250	230
7					200	160	140

LC424_V401_1116_MR800_CW200_STAB_100

[m] \ [kg]	 MR800.4-6+4P	 50%	 360°	 200kg	 EN		
	3,9	4,8	5,8	6,8	7,8	8,8	9,8
1	800	800	750	700			
2	800	700	700	670	640	600	540
3	640	600	550	500	450	430	400
4		400	390	390	330	310	300
5			230	220	210	200	190
6				110	100	100	100

LC424_V401_1116_MR800_CW200_STAB_50

JIB800.2H1MX

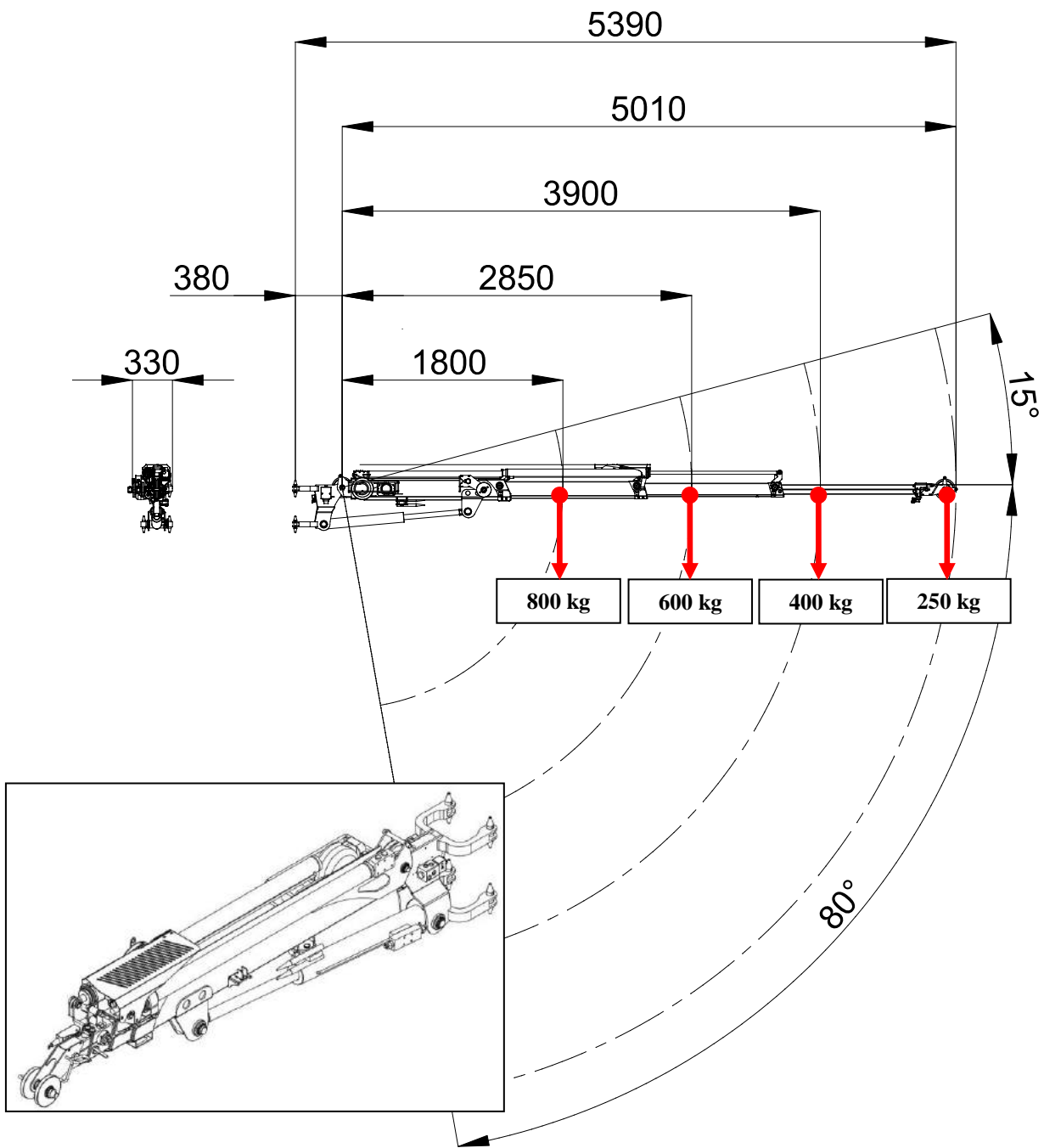

HEAD CONFIGURATIONS:

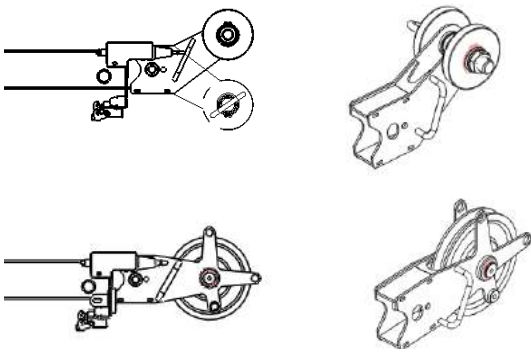

MR800.4-6+4P

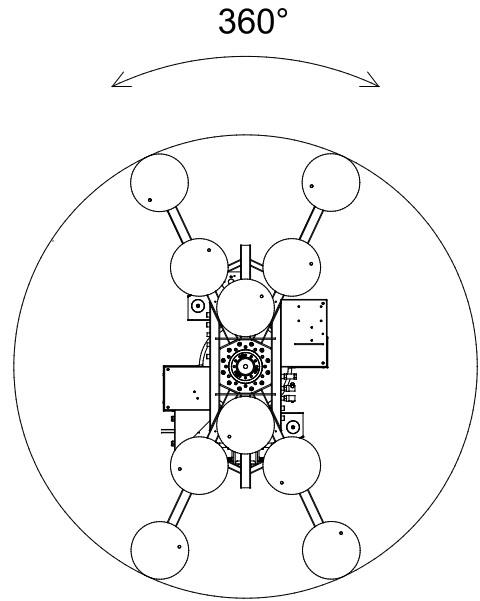
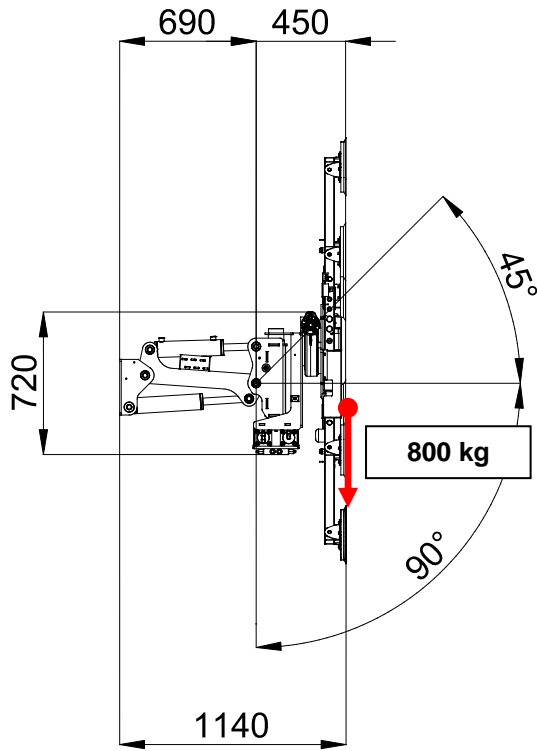



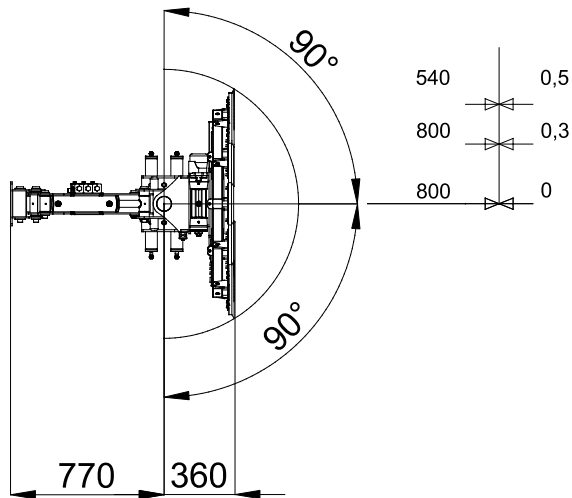













kg m



	6	10	n°
	540	800	kg
	270	400	kg

SYMBOLS

	Weight		Chart Wheels		Engine		Jib length and angle
	Counterweight		Minipicker		Diesel Fuel		Jib Length
	Crane		Back Wheel Point Loading		Gasoline Fuel		Jib Radius
	Travel Speed		Front wheel Point Loading		Tank		Hydraulic Jib Length
	Gradeability		Travel Speed		Battery		Hydraulic Jib Radius
	Outtrigger Load		Gradeability		Power		Mechanical Jib Length
	Track Loading		Working Radius		Boom Angle		Mechanical Jib Radius
	Outriggers Setup		Hookblock		Boom Length		Manipulator Length
	Ext Tracks Width		Slewing		Boom Radius		Manipulator Radius
	Chart On Tracks		Slewing Locked		Jib Hook Radius		Maximum inclination of the machinery
	Jib on board		Without jib on board		Standard		Stabilizing bar
	Horizontal boom angle		Number of vacuum pads		Factory max. load		Building site max. load
	Powerpack		Outriggers mats		Winter warm-up kit		Hydraulic oil

Remarks referring to load chart

- The load charts are calculated according to EN 13000.
- For the calculation of the load charts at least a wind speed of 9m/s (33km/h) and regarding the load a sail area of 1m² per ton load and a wind resistance coefficient of 1.2 on the load have been taken into account. For lifting of loads with large sail areas and/or high wind resistance coefficients the maximum wind speed as stated in the load charts has to be reduced.
- Lifting capacities are given in kilograms.
- The weight of the hook blocks and hooks is part of the load and therefore it must be deducted from the lifting capacities.
- Working radii are measured from the slewing centre.
- The lifting capacities given for the telescopic boom apply if the folding jib is removed.
- Subject to modification of lifting capacities.